

Webb Research Corporation

82 Technology Park Drive, E. Falmouth, MA 02536-4441 (508) 548-2077 FAX (508) 540-1686

USER MANUAL – APEX–SBE PROFILER

APEX–SBE INSTRUMENTS

REV DATE: 12/15/00

UW Riser Contract #: 223802

WRC Job no. 732

This manual applies to units with 260 cc pumps

With 07/28/00 Software

I.ALKALINE BATTERY WARNING.....	2
II.RESET AND SELF TEST.....	2
III.MOUNTING DAMPER PLATE.....	4
IV.DEPLOYMENT	4
V.ARGOS DATA.....	5
A.SERVICE ARGOS PARAMETERS.....	5
B.DATA FORMAT.....	6
C.TEST MESSAGE FORMAT.....	10
D.CRC.....	11
E.CONSTANTS.....	12
VI.RECORDS & CALIBRATIONS.....	14

I. ALKALINE BATTERY WARNING

The profiler contains alkaline "D" cells.

There is a small but finite possibility that batteries of alkaline cells will release a combustible gas mixture. This gas release generally is not evident when batteries are exposed to the atmosphere, as the gases are dispersed and diluted to a safe level. When the batteries are confined in a sealed instrument mechanism, the gases can accumulate and an explosion is possible.

Webb Research Corp. has added a catalyst inside of these instruments to recombine Hydrogen and Oxygen into H₂O, and the instrument has been designed to relieve excessive internal pressure buildup by having the upper endcap release.

Webb Research Corp. knows of no way to completely eliminate this hazard. The user is warned, and must accept and deal with this risk in order to use this instrument safely as so provided.

Personnel with knowledge and training to deal with this risk should seal or operate the instrument. Webb Research Corp. disclaims liability for any consequences of combustion or explosion.

II. Reset and Self Test

Profilers are shipped to the deployment site in Hibernate mode. Shortly before deployment, reset the profiler by passing a magnet over the marked location on the pressure case. The profiler will run a self-test, transmit for 6 hours with the bladder extended, and then begin its pre-programmed mission.

The six ARGOS transmissions during self-test and the transmissions during the initial 6 hour period contain data about the instrument and are outlined in (V) ARGOS DATA, part (C) TEST MESSAGE FORMAT.

Procedure:

1. Secure float in horizontal position, using foam cradles from crate.

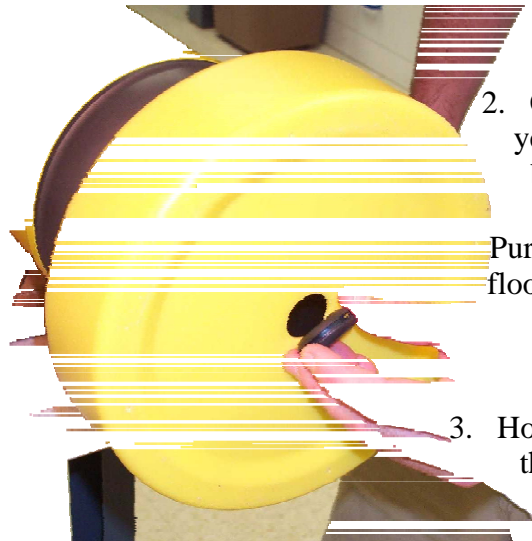

2. Carefully pry black rubber plug out of bottom center of yellow plastic cowling to verify bladder inflation (per below). **Be sure to replace plug before deployment.**

Purpose of plug is to prevent silt entry if float contacts sea floor.

3. Hold the provided magnet at RESET position marked on the hull for several seconds.

Note: The internal magnetic reed switch must be activated (held) for at least one second to reset the instrument. (This is to provide a safety against accidental reset during transport.) **Thus, if the float does not respond as below, the instrument was probably not reset.**

4. The air pump will operate for 1 second.
5. The PTT will transmit 6 times at 6 second intervals. Place the ARGOS receiver/beeper close to the antenna to detect transmissions.
6. The piston pump will begin to operate. The piston will move to the retracted Ballast Position, if not already there, pause 2 seconds and then move to full extension.
7. The oil bladder will expand, this should take 15 – 25 minutes.
8. After the piston pump stops, the air pump will inflate the air portion of the bladder taking 20 – 30 seconds. Verify bladder expansion by inserting finger into hole in cowling.
9. The PTT will transmit at the mission specified ARGOS rate.
10. 6 hours after reset, transmissions will cease, the piston pump will retract and the bladder will deflate, the profiler begins its programmed mission.
11. Reminder – replace black rubber plug in cowling hole before deployment.

During self-test, the controller checks the internal vacuum sensor. If the internal pressure has increased above a preset limit (i.e. hull leakage caused loss of vacuum), the instrument will not pump. If you do not detect the 6 test transmissions, and if the bladder does not inflate, then the self-test has failed and the instrument should not be deployed.

III. Mounting Damper Plate

To aid surface following, a square Plate is pre-mounted to the outside of the pressure case using 2 pvc collars, an O-ring, and titanium hardware. The damper parts should be ballasted with each instrument, and numbered accordingly. Below are instructions.

- Remove the float from the crate and secure horizontally on foam cradles.
- Unpack the appropriate numbered stability disk.
- Remove the titanium hardware and one gray collar.
- Sandwich the clear disk between 2 gray collars.
- NOTE: the chamfered edge of the collar must be toward the O-ring as shown below.
- Install 6 bolts firmly – use 2 flat washers for each bolt, one on each side of collar.
- Using two wrenches, tighten the second nut against the first to lock fasteners in place.
- Note: Be sure to use the hardware particular to each instrument.

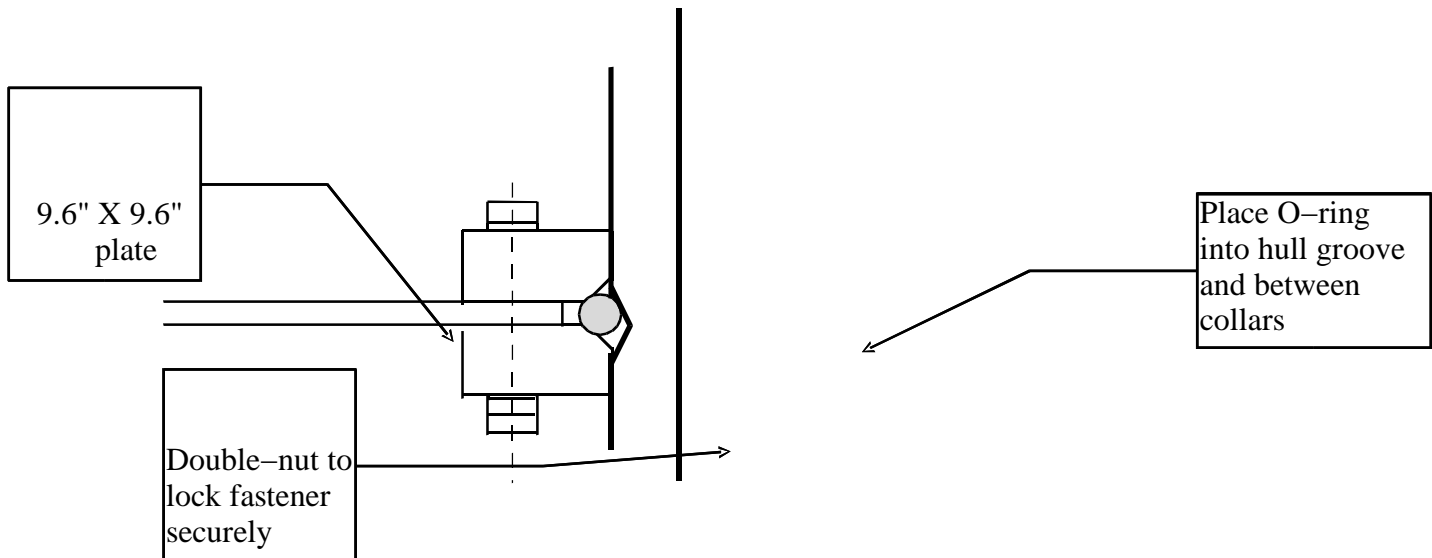

IV. Deployment

- RESET instrument.
- SELF-TEST starts automatically (see above).
- When piston pump stops, air pump inflates, external bladder is full, PTT will transmit for 6 hours at ARGOS Repetition rate intervals. Normally 90 seconds.
- Six hours after reset, the piston pump will retract and bladder will deflate. Deploy before this time is up or reset the instrument again to re-initialize the 6 hour period. The purpose is to have the instrument on the surface and receive test transmissions.
- Pass a rope through the hole in the stability plate.

- Holding both ends of the rope, carefully lower the float into the water.
- Take care not to damage the antenna.
- Do **not** leave the rope with the instrument, release one end and retrieve the rope.
- The float will remain on the surface until the 6 hour interval has expired.

V. ARGOS DATA

A. SERVICE ARGOS PARAMETERS

The user must specify various options to Service ARGOS. These choices depend on how the user wishes to receive and process data. Typical parameters are listed below:

- Standard location.
- Processing: Type A2 (pure binary input; hexadecimal output)
- Results Format: DS (all results from each satellite pass), Uncompressed.
- Distribution Strategy: Scheduled, all results, every 24 hours.
- Number of bytes transmitted: 32

Note: Webb Research recommends all users to use ARGOS "Multi Satellite Service", which provides receptions from 3 satellites instead of 2 for a small incremental cost.

B. DATA FORMAT

Data is sent via ARGOS in 32 byte hex messages. The number of 32 byte messages sent depends on the programmed quantity of temperature measurements per profile

Format for message number 1 only:

Byte #

- 01 **CRC**, described in section C.
- 02 **Message number**, Assigned sequentially to each 32 byte message (Total number of messages per profile is shown below). Messages are transmitted in sequential order starting with 1 and incrementing by one for the data set.
- 03 **Message block number**, begins as 1 and increments by one for every ARGOS message data set. This, combined with the ARGOS repetition rate (section VI), allows the user to track surface drift. Byte 03 will roll-over at 256 and will reset to 1 on each new profile.
- 04 & 05 **Serial number**, identifies the controller board number. (This may not be the same as instrument number.)
- 06 **Profile number**, begins with 1 and increases by one for every float ascent.
- 07 **Profile length**, is the number of six byte STD measurements in the profile. Total number of bytes of STD data from each profile depends on the sampling strategy chosen.
- 08 **Profile termination flag byte**, can have the following values (hex):
 - 00 Pressure reached surface pressure.
 - 02 Pressure reached zero.
 - 4 Pressure unchanged for 25 minutes. (Does not terminate profile.)
 - 8 Piston fully extended before surface
- 09 **Piston position**, recorded as the instrument reaches the surface.
- 10 & 11 **Pump motor time**, in two second intervals
- 12 **Battery voltage**, at initial pump extension completion
- 13 **Profile piston position**, in counts (Park and profile only)
- 14 **Surface piston position**, in counts
- 15 **Air bladder pressure**, in counts
- 16 & 17 **Bottom temperature**, sampled just before instrument begins ascent.
- 18 & 19 **Bottom salinity**, sampled just before instrument begins ascent.
- 20 & 21 **Bottom pressure**, sampled just before instrument begins ascent.
- 22 **Battery voltage**, no load.
- 23 & 24 **Surface pressure**, as recorded just before last descent with an offset of +5db.
- 25 **Internal vacuum**, as recorded just before last descent.
- 26 **Piston position at bottom**, in counts
- 27 to 32 6 bytes in sequence:
 - 2 bytes **temperature**
 - 2 bytes **salinity**
 - 2 bytes **pressure**

Format for message number 2 and higher:

Byte #

- 01 **CRC**, described in section C.
- 02 **Message number**
- 03 to 32 6 bytes in sequence:
 - 2 bytes **temperature**
 - 2 bytes **salinity**
 - 2 bytes **pressure**

Message Format and Sampling Depths

BTYE #	MSG 1
16 & 17	Tb*
18 & 19	Sb*
20 & 21	Pb*
23 & 24	Ps**
27 & 28	T1***
29 & 30	S1***
31 & 32	P1***

BTYE #	MSG 2	MSG 3	MSG 4	MSG 5	MSG 6	MSG 7	MSG 8
3 & 4	T2	T7	T12	T17	T22	T27	T32
5 & 6	S2	S7	S12	S17	S22	S27	S32
7 & 8	P2	P7	P12	P17	P22	P27	P32
9 & 10	T3	T8	T13	T18	T23	T28	T33
11 & 12	S3	S8	S13	S18	S23	S28	S33
13 & 14	P3	P8	P13	P18	P23	P28	P33
15 & 16	T4	T9	T14	T19	T24	T29	T34
17 & 18	S4	S9	S14	S19	S24	S29	S34
19 & 20	P4	P9	P14	P19	P24	P29	P34
21 & 22	T5	T10	T15	T20	T25	T30	T35
23 & 24	S5	S10	S15	S20	S25	S30	S35
25 & 26	P5	P10	P15	P20	P25	P30	P35
27 & 28	T6	T11	T16	T21	T26	T31	T36
29 & 30	S6	S11	S16	S21	S26	S31	S36
31 & 32	P6	P11	P16	P21	P26	P31	P36

BTYE #	MSG 9	MSG 10	MSG 11	MSG 12	MSG 13	MSG 14	MSG 15
3 & 4	T37	T42	T47	T52	T57	T62	T67
5 & 6	S37	S42	S47	S52	S57	S62	S67
7 & 8	P37	P42	P47	P52	P57	P62	P67
9 & 10	T38	T43	T48	T53	T58	T63	T68
11 & 12	S38	S43	S48	S53	S58	S63	S68
13 & 14	P38	P43	P48	P53	P58	P63	P68
15 & 16	T39	T44	T49	T54	T59	T64	T69
17 & 18	S39	S44	S49	S54	S59	S64	S69
19 & 20	P39	P44	P49	P54	P59	P64	P69
21 & 22	T40	T45	T50	T55	T60	T65	T70
23 & 24	S40	S45	S50	S55	S60	S65	S70
25 & 26	P40	P45	P50	P55	P60	P65	P70
27 & 28	T41	T46	T51	T56	T61	T66	FFFF
29 & 30	S41	S46	S51	S56	S61	S66	FFFF
31 & 32	P41	P46	P51	P56	P61	P66	FFFF

* Tb, Sb, and Pb are bottom Temperature, Salinity, and Pressure values

** Ps is surface Pressure

*** T, S, and P are Temperature, Salinity, and Pressure values

**** **FFFF**: Invalid data points

Data format table above assumes that bottom pressure (maximum hydrostatic pressure at start of profile) is 2000dbar. Data format will change if bottom pressure varies.

APEX records a profile during ascent (ie upcast). Bottom pressure may change due to several causes, such variation of insitu density, internal waves, float grounding in shallows, change of float mass, etc. APEX automatic depth adjustment will compensate in most, but not all, cases. Actual bottom pressure is transmitted as bytes 20 & 21 of message one.

Number of sample points is proportional to depth, as per sample depth table on page 9.

The first (i.e. deepest) sample is taken at the first point in the depth table above bottom pressure, and is designated as T1, S1, P1 in the table above.

Depth Table No. 26

Sample Point	Pressure (dbar)	Sample Point	Pressure (dbar)	Sample Point	Pressure (dbar)
	Bottom				
1	2000	27	700	53	180
2	1950	28	650	54	170
3	1900	29	600	55	160
4	1850	30	550	56	150
5	1800	31	500	57	140
6	1750	32	450	58	130
7	1700	33	400	59	120
8	1650	34	380	60	110
9	1600	35	360	61	100
10	1550	36	350	62	90
11	1500	37	340	63	80
12	1450	38	330	64	70
13	1400	39	320	65	60
14	1350	40	310	66	50
15	1300	41	300	67	40
16	1250	42	290	68	30
17	1200	43	280	69	20
18	1150	44	270	70	10
19	1100	45	260	71	4 or Surf.
20	1050	46	250		
21	1000	47	240		
22	950	48	230		
23	900	49	220		
24	850	50	210		
25	800	51	200		
26	750	52	190		

* The SeaBird CTD is not sampled at zero pressure, to avoid pumping the cell dry and/or ingesting surface oil slicks. The shallowest profile point is taken at either 4 dbar or at the last recorded surface pressure plus 5 dbar, whichever value is larger.

C. TEST MESSAGE FORMAT

The test message is sent whenever an **I2** command is given, the six transmissions during the startup cycle, and during the six hour surface mode period prior to the first dive. Each test message has 32 bytes, in hex unless otherwise noted, with the following format:

Byte #

- 01 **CRC**, described in section C.
- 02 **Message block number**, begins as 1 and increments by one for every ARGOS message.
- 03 & 04 **Serial number**, identifies the controller board number. (This may not be the same as instrument number.)
- 05 **Hour**, the following is the time from startup (in decimal).
- 06 **Minutes**.
- 07 **Seconds**.
- 08 **Flag (2) byte**, see below
- 09 & 10 **Current pressure**.
- 11 **Battery voltage**, nominally at 15 volts.
- 12 **Current bladder pressure**, in counts
- 13 **Flag (1) byte**, see below
- 14 **Up time**, intervals
- 15 & 16 **Down time**, intervals
- 17 **Trip interval time**, hours.
- 18 & 19 **Profile pressure**, in centibars
- 20 **Profile piston position**, in counts
- 21 **Depth correction factor**, in counts
- 22 **Ballast piston position**, in counts
- 23 **Fully extended piston position**, in counts
- 24 **OK vacuum count at launch**, nominally 2 inches HG
- 25 **Ascend time**, intervals
- 26 **Target bladder pressure**
- 27 & 28 **Park pressure**, (for use in park and profile floats only)
- 29 **Park piston position**, (for use in park and profile floats only)
- 30 **Month**, software version number (in decimal).
- 31 **Day**, software version number (in decimal).
- 32 **Year**, software version number (in decimal).

Flag (2) Byte

Flag (1) Byte

Bit		Bit	
1	Unused	1	Trip interval time
2	Pressure reached zero	2	Profile in progress
3	25 minute next Press time out	3	Timer done
4	Piston fully extended	4	UP/DOWN
5	Ascend time out	5	Data entry error
6	Test message at turn on	6	Unused
7	Six hour surface message	7	Piston motor running
8	Arithmetic round up	8	Negative SBE number

D. CRC

Because ARGOS data may contain transmission errors, the first byte of each message contains an error checking value. This value is a Cyclic Redundancy Check (CRC), and is calculated as a function of the message content (bytes 2 to 32).

- For each message, calculate a CRC value
- Compare the calculated CRC to the transmitted CRC (byte no. 1)
- If the calculated and transmitted CRC values are not equal, the message has been corrupted and should be deleted before further data processing.

Below is a sample program (in BASIC) to calculate the CRC value for a message. This program can be provided upon request in Basic, Fortran or C.

```

DECLARE FUNCTION CRC% (IN() AS INTEGER, N AS INTEGER)
'CRC routine to check data validity in ARGOS message.
'Bathy Systems, Inc. RAFOS Float data transmission.
'3 December, 1990.
'The 1st of 32 bytes in an ARGOS message is the CRC.
'The function CRC will compute CRC for byte 2 through 32.
'Hasard is used for Random because Random is reserved by BASIC.
'Stored as file CRC in C:\RAFOS\RAF11.
DECLARE SUB Hasard (ByteN AS INTEGER)
DEFINT A-Z
DIM in(32) AS INTEGER
'RAF11F message number 08 HEX ID 11502 01-02-93  CRC is O.K.
A$ = "8F00081C8E47239148A4D2E9743A1D0E070381C06030984C2693492492C964B2"

      N = 32
      FOR I = 1 TO N
          in(I) = VAL("&H" + MID$(A$, 2 + I - 1, 2))
      NEXT I
      PRINT in(1); CRC(in(), N);

FUNCTION CRC% (IN() AS INTEGER, N AS INTEGER) STATIC
DIM ByteN as INTEGER
      I = 2
      ByteN = in(2)
      DO
          CALL Hasard(ByteN)
          I = I + 1

```

```

        ByteN = ByteN XOR in(I)
    LOOP UNTIL I = N
    CALL Hasard (ByteN)
    CRC = ByteN
END FUNCTION

```

```

DEFINT A-Z
SUB Hasard (ByteN AS INTEGER) STATIC
x% = 0
    IF ByteN = 0 THEN ByteN = 127: EXIT SUB
    IF (ByteN AND 1) = 1 THEN x% = x% + 1
    IF (ByteN AND 4) = 4 THEN x% = x% + 1
    IF (ByteN AND 8) = 8 THEN x% = x% + 1
    IF (ByteN AND 16) = 16 THEN x% = x% + 1
    IF (X% AND 1) = 1 THEN
        ByteN = INT(ByteN / 2) + 128
    ELSE
        ByteN = INT(ByteN / 2)
    END IF
END SUB

```

E. CONSTANTS

The pressure is measured every 6 seconds. Temperature, salinity and pressure are measured and stored at each point in the depth table.

Two hex bytes are stored for each sensor. The decimal numbers from the STD sensors are converted to hex for compression in the ARGOS transmission as follows:

Temperature: first 5 digits, 1 milli-degree resolution.
 Salinity: 5 digits
 Pressure: first 5 digits, 10 cm resolution.

To convert the hex ARGOS message back to decimal numbers:

	<u>hex</u>	<u>→</u>	<u>dec</u>	<u>=</u>	<u>converted</u>	<u>units</u>
Temperature:	3EA6	→	16038	=	16.038	C
Temperature*:	F58B	→	02677	=	-2.677	C
Salinity**:	8FDD	→	36829	=	36.829	
Pressure:	1D4C	→	7500	=	750.0	decibars

*Any minus temperatures are 2s complemented. -0.1808 rounds to -0.181 and converts to FF4B. (181 is B5 hex and 0 - B5 = FF4B.) Positive temperatures will take the range of 0 to 62.535C (0 to F447hex) and negative temperatures will take the range of -0.001 to -3.000C (FFFF to F448hex). In practice the positive temperatures work from 0 hex up and the negative temperatures work from FFFF hex and down.

**The 5 most significant salinity digits are telemetered. The 6 digit salinity number is rounded up and converted to hex. 36.8286 rounds to 36.829 and converts to 8FDD.

Voltage (V) = counts/10 + .6 (counts is in decimal number) nominally 15 V and decreasing.
Vacuum (inHg) = counts * -0.376 + 29.15 (counts is in decimal number) nominally 5 inHg.

VI. RECORDS & CALIBRATIONS